

Übersicht/ Profile Range/ Vue d'ensemble:

TROCAL InnoNova_70.M5

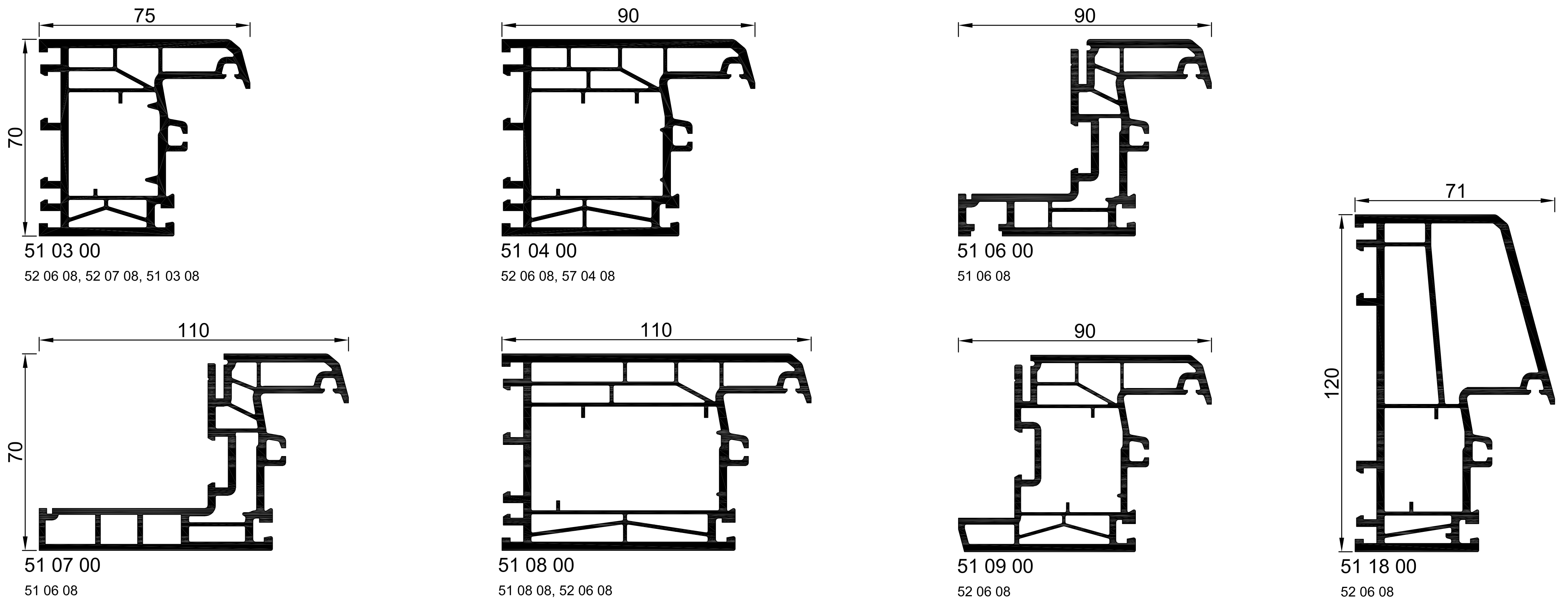

Blendrahmen / Outer Frames / Dormants



Flügel / Sashes / Ouvrants

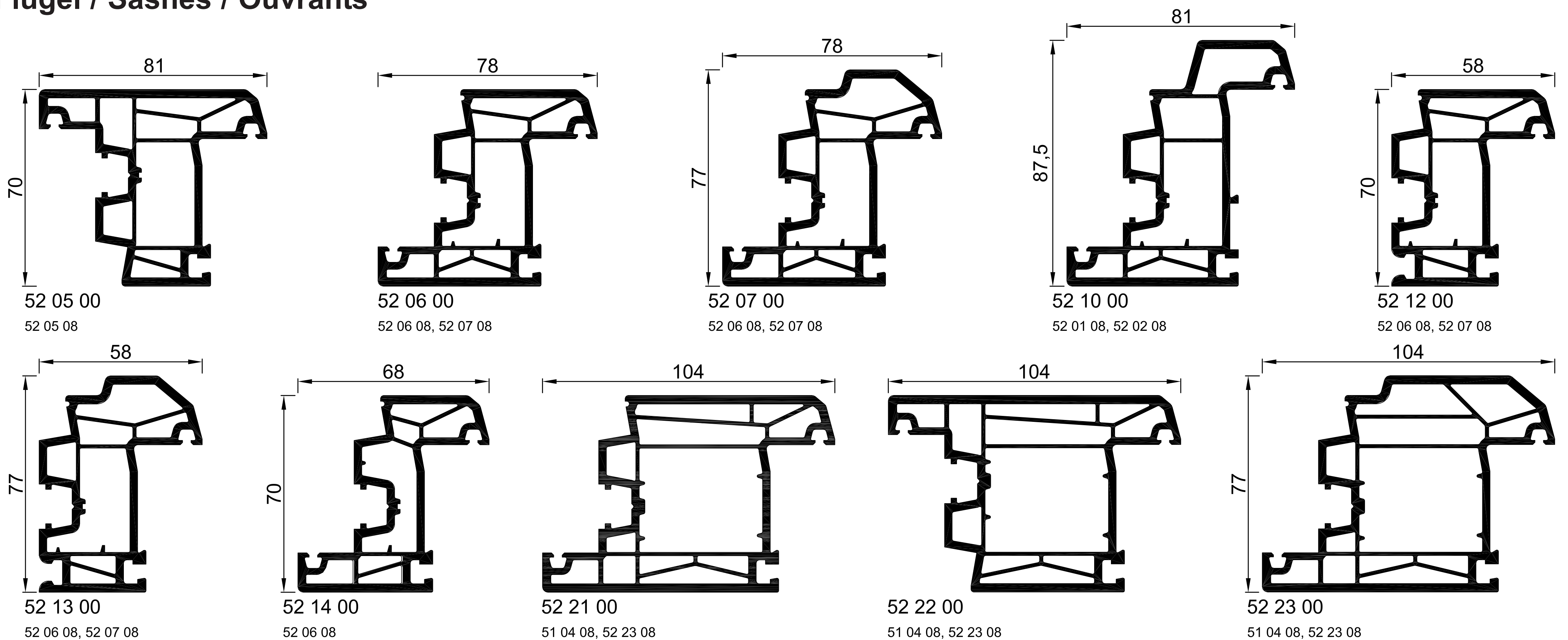

Pfosten + Kämpfer / Mullions + Transoms / Meneaux + Traverses

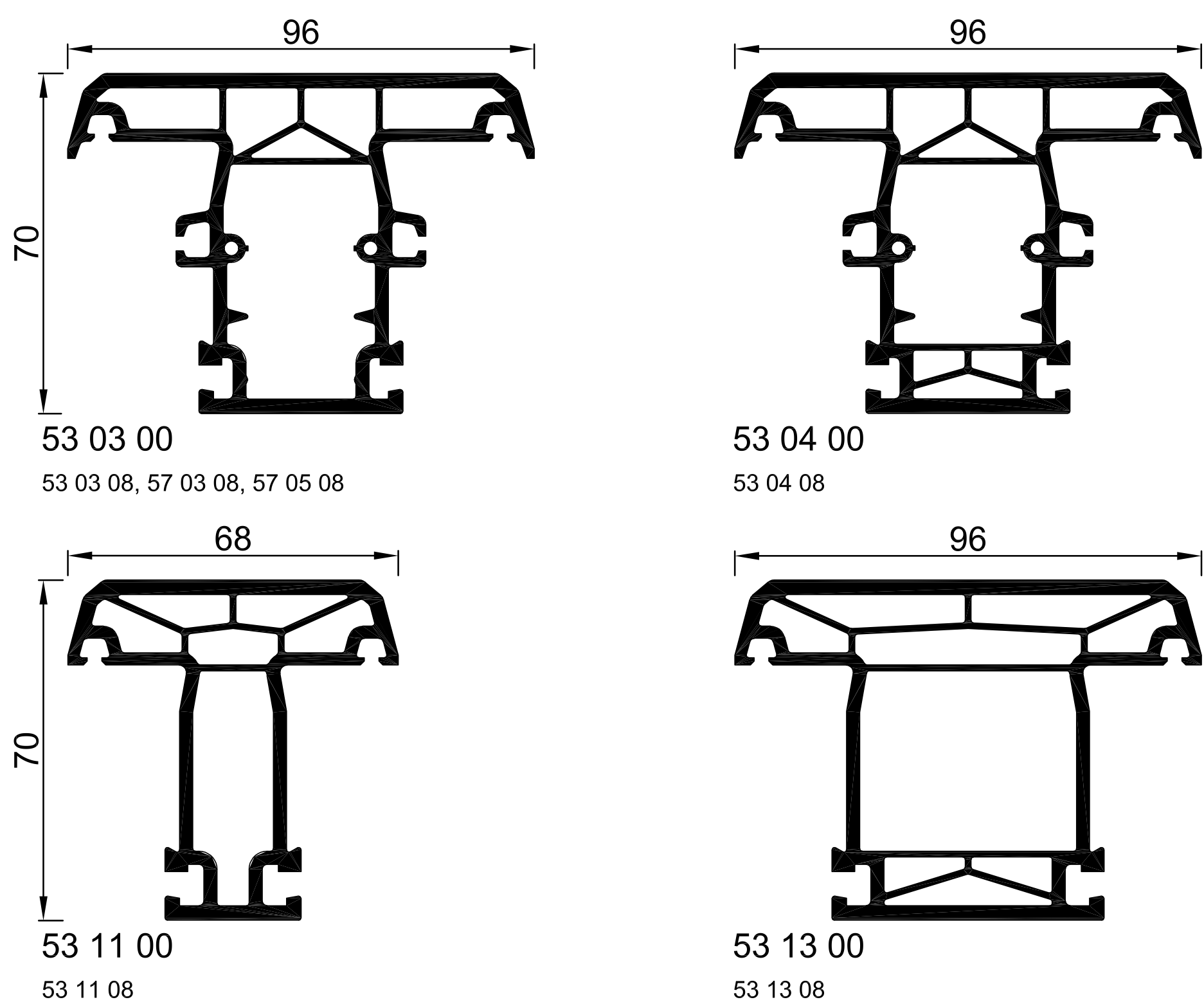

Stulpprofile / Dummy Mullions / Battement

